

be the first.



Technical data

BASIC DATA

ERC 63/x-E (EH)

ERC 73/x-E (EH)

ERC 83/x-E (EH)

ENGEL AUSTRIA GmbH
Zweigniederlassung Dietach
A-4407 Dietach Ludwig-Engel-Strasse 1
Fon: +43 7262 620-0 Fax: +43 7262 620-3359
E-Mail: sales@engel.at www.engel.info

ENGEL
roboter

STANDARD EQUIPMENT

Mechanics:

- Compact low construction
- Y-tandem axis, standard for Vertical stroke
- Helical and permanently greased gear racks in the Z- and Y-axis
- Low-noise energy chains
- Torsion-stiff vertical stroke
- Mounting on the fixed mould fixing platen (with Z support at EH)
- Depositing of the parts alternatively on the front or rear side of the machine (Definition when ordering)
- 3 freely positionable servo axes
- Hardened, ground and low-maintenance precision guides
- Drive by means of highly dynamic, maintenance-free three-phase servomotors
- Swivelling module (C-axis) 0-90° pneumatic, 125Nm

pneumatics:

- Air maintenance unit with shut-off valve
- Central valve ramp with direct CAN bus connection
- 2 switchable sucker / gripper circuits
- Per sucker/gripper circuit: 1 Parts, 2 end positions and 1 vacuum monitoring
- 2 End position monitoring per pneumatic circuit
- Vacuum production via Venturi nozzle
- Connection of the gripping and suction elements via pneumatic quick-action couplings

Electric system:

- Control cabinet alternatively free-standing or integrated into the injection moulding machine
- Electric plug for takeover head (standard 25-pole D-Sub)
- 1 Conveyor-belt socket for stepping operation (depositing belt and rejects or control part belt) 3-phase, 6A
- Electric preparation for access door and external emergency stop
- digital in and outputs can be retrofitted individually
- Plug-in limit switches

CONTROL SYSTEMS

RC 100

- Standard control for a robot
- For integrated applications (CPU integrated in the control cabinet)
- Option for complex standalone applications
- Input medium: 3 1/2" diskette
- Flexible manual control device with LCD display
- Connection of different manual control devices possible (HBG2, HBG3)

MANUAL CONTROL DEVICES

HBG 2

- Standard manual control device for integrated execution
- Two-line display for the actual value and error display
- Emergency stop switch

Control system RC 100:

- Axis control with linear interpolation and rapid overgrinding in all axes
- 64 Bit RISC computer
- CAN bus for drive connections and in/output modules
- Parameter input via the control panel of the ENGEL machine control unit
- Common data protection of handling system, machine and mould parameters on one data carrier
- Screen texts possible in almost all national languages
- Plain language display of machine errors, waiting messages and plant status on the machine screen
- Actual value and error display in addition on the manual control device (HBG 2)
- Automatic referencing
- Automatic and teachable home run in the start position
- Structured, navigateable handling system setup
- Status page for state visualization of the whole handling system, with diagnostics and test
- Central language and unit switchover (for integrated systems)
- Diversion of the print files into a file
- Continuation of the sequence in the automatic cycle after an interruption (repositioning)
- Takeover of the current handling system position into the program (Quickset)
- Approach of a set position in the manual mode (quick pos.)
- Cycle time saving by early start of the handling system at the take-off

Program package for standard applications:

- Free input of axis speeds, positions and times
- Take-off from moving and fixed mould half
- Vacuum circuits with underpressure monitoring
- Gripper circuits with monitoring of parts and end positions
- Pneumatic circuits with monitoring of end positions
- Variable ejector control via freely adjustable control times
- Rejects separation (good/bad - according to Euromap)

RC 511

- For Standalone applications
- Program volume like at RC 100
- Control system integrated into the HBG (manual control device)
- max. 2 CAN bus connections
- Control of a drive unit (6 axes)
- Input medium: Flash Card
- 1 Interface RS-422A
- Monochrome screen
- Connection for printer and external diskette drive

HBG 3

- Manual control device with monochrome screen for integrated as well as Standalone applications with RC100 control system
- Operation of the robot possible like on the machine terminal
- emergency stop

- Quality control
- Sprue separation
- Depositing in intermediate position for secondary finishing (imprinting, milling etc.)
- Stacking with intermediate layers
- Adjustable swivelling area in the vertical stroke Y (for swivelling axes and axes of rotation)
- Free input of the depositing screen in X-Y-Z with processing priorities
- Service interval display (kilometer counter)
- Program test with Step-by-Step

Teach-In program package:

- Free creation of max. 20 programs per sequence; can be used as sub-program or parallel program
- Page of variables and diagnostics with state control (ABC axes, suckers, grippers, etc.)
- Program sequence control
- Representation mode which can be switched over for Teach-In editor (individual/list representation)
- Relative and absolute moving instructions
- Free establishment of depositing screens (space optimization)
- Free inclusion of menu programs, such as: Take-off, rejects, quality control, depositing, etc.
- Free inclusion of in/outputs for special grippers or peripheral unit
- Plain language designations for all variables (markers, counters, etc.)
- Programmable home run from a critical area of the sequence in the start position (teachable home run)

Off Limit program package:

- Workroom monitoring as collision protection for: Injection moulding machine, robot, takeover head, mould, safety gate, in the depositing area for peripheral unit, conveyor-belt, balance, etc.
- Machine- and mould-specific workrooms

Mounting on foreign machine (Standalone):

- Manual control device with VGA display and touch-sensitive keyboard (HBG 3)
- Flash card as input medium
- Interface according to Euromap 12
- Control cabinet free-standing

SPECIAL EQUIPMENT

Mechanics:

- Protection fence according to EN 294
- Extension of the Z-axis: in steps of 480 mm each
- Y-tandem stroke with 1000, 1400, 1800, 2200 mm
- Increased drive power for Y-axis
- Frame support with increased Drive power
- Z support incl. machine support pad
- Depositing on machine longitudinal side
- GRIP TOOLS: Modular system for takeover heads
- Fast change system for takeover head: manual / semiautomatic / fully automatic
- Sprue nippers (pneum.) on the cross-girder
- automatic central lubrication

Axes of rotation:

- C-TURNING, pneu, (0-90°)
- C-TURNING, servo (0-180°)
- B-TURNING, pneu, (0-90°/180°)
- B-TURNING, servo, (0-270°)
- A-TURNING, pneu, (0-90°/180°)
- A-TURNING, servo, (0-270°)

pneumatics:

- max. 8 additional sucker/gripper circuits (can be switched over)
- Additional compressed air circuits
- Vacuum pump instead of Venturi nozzle

Peripheral unit:

- Peripheral units with full integration in the menu program and free inclusion in Teach-In sequences
- Secondary finishing equipment fully integrated
- Balance for online weight examination and protection of the quality data

Electric system:

- Safety packages for safety guarding which can be entered from behind (alternatively with/without)
- Safety package 3 for the production with open rear safety gate (only at integrated version)
- Special voltage
- Interface peripheral unit for 3 zero-potential signals (with emergency stop and protection doors open)
- Electric connection 2-pole, 10A
- Electric connection 3-pole, 16A
- Interface on the Z carrier in plug-in execution

Special programs control:

- Clearing switch for the depositing conveyor-belt
- Take-off stroke correction: Correction of the take-off position by the mold actual position (only for integrated version)
- Release for mould or hall crane
- Take-off at mould intermediate stop (only at IMM support)
- Cylinder for space optimization
- Moving area limitation: electric safeguarding of the moving area within the IMM (X-Z safeguarding)
- Program for the communication with a balance
- Program for sprue gripper
- Horizontal/vertical take-off can be switched over
- Torque monitoring
- Synchronous process with mould or ejector
- Softservo (Take-off and/or insert-placing with plasticized force)
- Separate control of the core-pulls
- Interface for central computer (version ENGEL)
- Program test without IMM function (dry operation)

Technical data

TYPE		63/x-E	63/x-EH	73/x-E	73/x-EH	83/x-E	83/x-EH
manipulable mass max.	kg	30 ^a / 50 ^b	20 ^a / 40 ^b	30 ^a / 50 ^b	20 ^a / 40 ^b	30 ^a / 50 ^b	20 ^a / 40 ^b
Repeatability	mm	± 0,05	± 0,05	± 0,05	± 0,05	± 0,05	± 0,05
X-AXIS (demoulding stroke)	STANDARD mm	700	700	1000	1000	1300	1300
X-AXIS (demoulding stroke)	OPTION	1000/1300	1000/1300	1300	1300	-	-
X speed max.	m/s	2,5	2,5	2,5	2,5	2,5	2,5
Y-AXIS (tandem)	STANDARD	1000	1000	1400	1400	1800	1800
Y-AXIS (tandem)	OPTION	1400/1800/ 2200 ^c	1400/1800/ 2200 ^c	1800/ 2200 ^c	1800/ 2200 ^c	2200 ^c	2200 ^c
Y speed max.	m/s	3	4	3	4	3	4
Z-AXIS (cross transport)	STANDARD mm	1880	1880	2360	2360	2360	2360
Z-AXIS (extension)	OPTION	1x480 - max.13x480	1x480 - max.13x480	1x480 - max.12x480	1x480 - max.12x480	1x480 - max.12x480	1x480 - max.12x480
Weight per 480mm Z stroke extension	kg	65	65	65	65	65	65
Z speed max.	m/s	3	3	3	3	3	3
C-AXIS (0-90°) pneu.	STANDARD Nm	125	125	125	125	125	125
C-AXIS (0-180°) servo	OPTION Nm	125	125	125	125	125	125
B-TURNING (0-90°/180°) pneu.	OPTION Nm	20	20	20	20	20	20
B-TURNING (0-270°) servo	OPTION Nm	110	110	110	110	110	110
A-TURNING (0/90°-180°) pneu.	OPTION Nm	20	20	20	20	20	20
A-TURNING (0-270°) servo	OPTION Nm	45	45	45	45	45	45
AIR CONSUMPTION ^d	L/min	15 / 68	15 / 68	15 / 68	15 / 68	15 / 68	15 / 68
Connected load	kVA	5	5	5	5	5	5
Transport weight robot	STANDARD kg	1280	1280	1350	1350	1350	1350
Transport weight control cabinet	kg	210	210	210	210	210	210

- only with C-axis (other allowed axis combinations - see data sheet ABC-axes)
- without C-axis
- reduced dynamics and/or reduced manipulation mass
- per cycle in litre / per suction nozzle in litre/min
E device = 30 sec cycle with 40% duty cycle with one suction circuit at 6 bar
EH device = 15sec cycle with 40% continuous duty with a suction circuit at 6 bar

DIMENSIONS

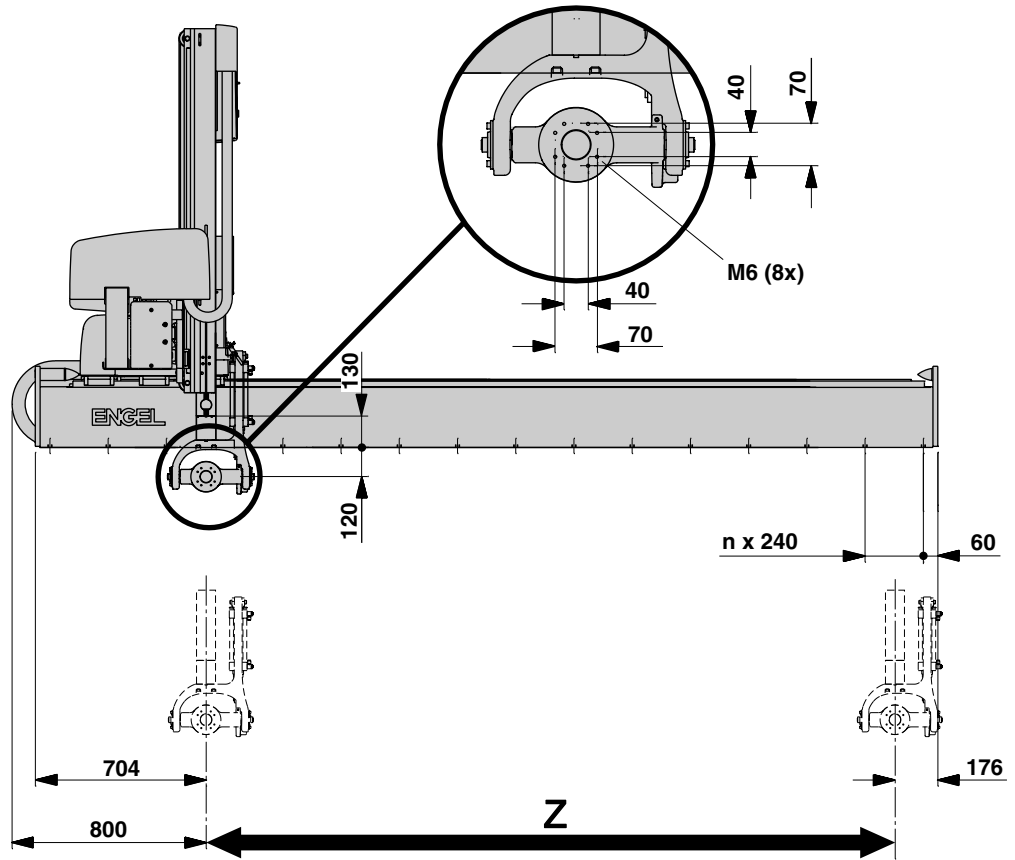

Line connections

ø 6 mm
ø 8 mm

Takeover head plug:
25 pole D-sub

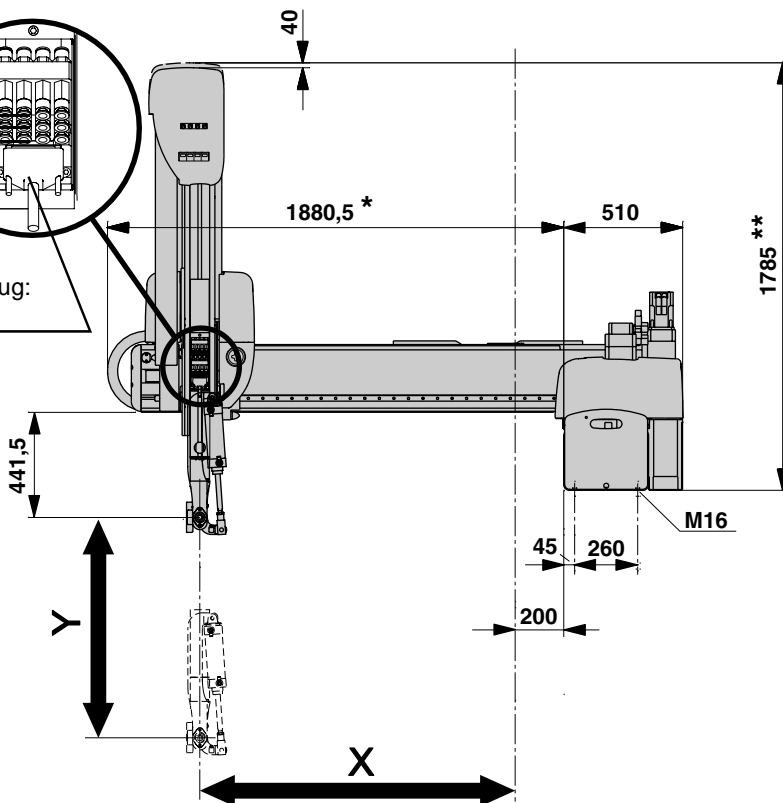

* X = 1300 mm

** Y = 2 x 900 mm

br14_082a