

Size designation		ES .../550TL		ES .../660TL	
		Imperial	Metric	Imperial	Metric
Clamping force	US tons/kN	550	5000	660	6000
Opening stroke	Inches /mm	47.24	1200	47.24	1200
Minimum mold height	Inches /mm	19.69	500	19.69	500
Maximum daylight	Inches /mm	66.93	1700	66.93	1700
Wide platen "C"	Inches /mm	62.20 x 51.18	1580 x 1300	62.20 x 51.18	1580 x 1300
Free drop clearance	Inches /mm	41.34	1050	41.34	1050
Ejector stroke	Inches /mm	9.84	250	9.84	250
Ejector force	US tons/kN	12.33	110	12.33	110

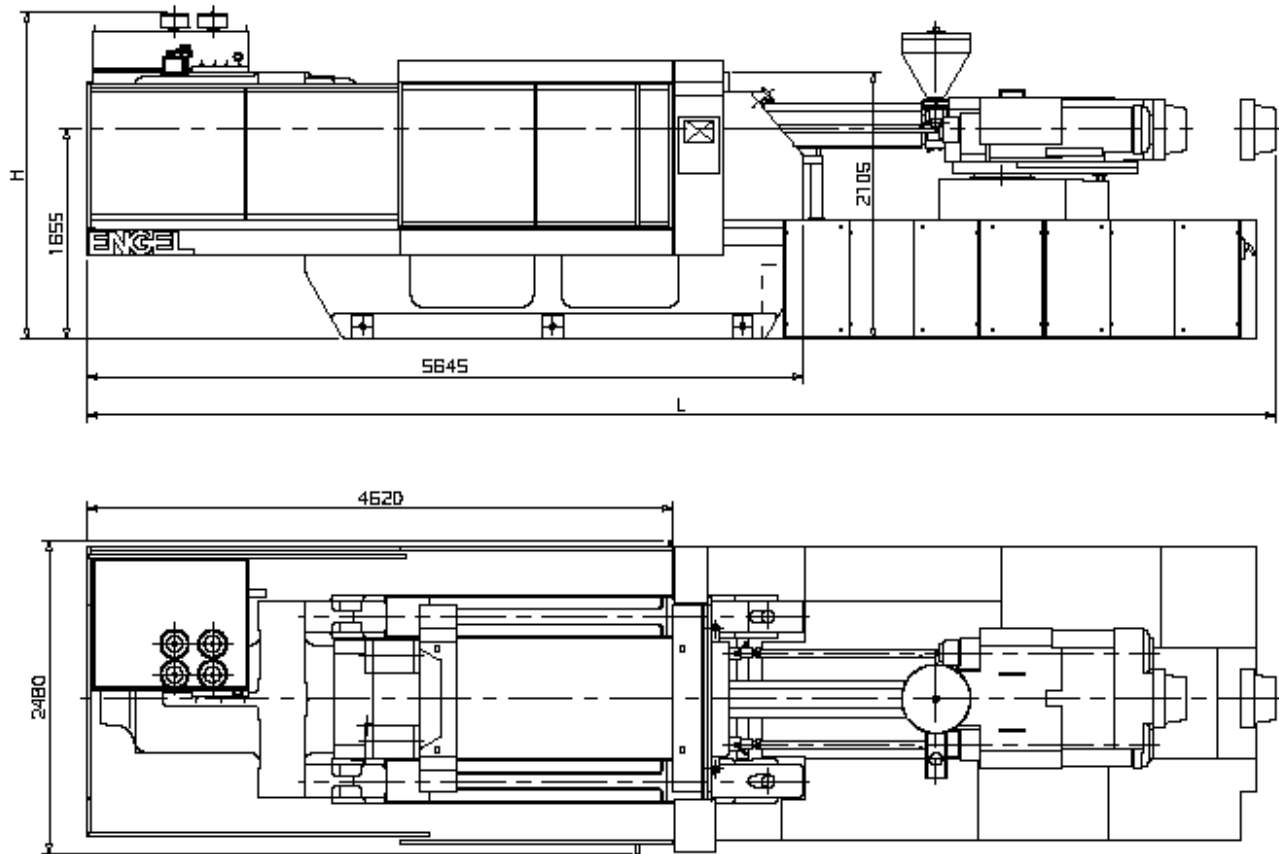

Various combinations and measurements of the standard clamping units

Machine designation	Dry Cycle	Weight, Clamp/Injection	L	H
	Seconds at 400mm stroke / in	US Tons	In/mm	In/mm
ES 2050 / 550 – 660	3.6/23.6	41/ 8	370.5/9410	101.6/2580
ES 2550 / 550 – 660	3.6/23.6	41/ 8	370.5/9410	101.6/2580
ES 3550 / 550 - 660	3.6/23.6	41/11	370.5/9410	101.6/2580
ES 4550 / 550 - 660	3.6/23.6	41/11	381.9/9700	101.6/2580
ES 7050 / 550 - 660	3.6/23.6	41/19	414.2/10520	101.6/2580

The equipment features are valid for the following Machines

Tie-barless machines:

ES 2050 / 550 TL CC100 A03
 ES 2550 / 550 TL CC100 A03
 ES 3550 / 550 TL CC100 A03
 ES 4550 / 550 TL CC100 A03
 ES 7050 / 550 TL CC100 A03

ES 2050 / 660 TL CC100 A03
 ES 2550 / 660 TL CC100 A03
 ES 3550 / 660 TL CC100 A03
 ES 4550 / 660 TL CC100 A03
 ES 7050 / 660 TL CC100 A03

Standard Equipment

- 3 Speeds for opening and closing
- Set-up
- Hydraulic ejector with tip stroke
- Mechanical safety device
- Hydraulic mold safety with monitoring
- Electric and hydraulic closing safety with monitoring
- Proportional valve on the clamping unit
- Platen ejector
- Safety gate

Hydraulics

- Energy saving electrically controlled variable displacement smart pump hydraulic system
- Hydraulic circuit with oil preheating, temperature control, oil level monitoring
- Pump station with locking mechanism and monitoring
- Permanent, oil sparing bypass filtration and cooling
- Parallel movement for ejector, core-pull and unit

Additional Options Available

- Extended safety gates
- Electric frequency driven safety gate
- Automatic safety gate
- Core-pull equipment single and multiple, hydraulic or pneumatic
- Solenoid air valves, function freely programmable
- Mold mounting crane
- Unscrewing device
- Preparation of mold shut-off devise
- Part drop detection Sensor
- Mold height increase
- Increased horizontal part drop area on WP
- Clean room equipment

Hydraulics

- Accumulators for faster cycling
- Increased drive power (N execution)
- Increased cooling capacity
- Connections for external filter station

Automation modules

- High speed mold mounting devise
- Mold change systems
- Robot systems

